

tapflo®

CTS SELF-PRIMING CENTRIFUGAL PUMPS

edition 2015 rev 1



» All about your flow

www.tapflo.com

CTS

self-priming centrifugal pumps

CTS is an open impeller self-priming centrifugal pump, manufactured from AISI 316L stainless steel.

CTS H with excellent electro polished surfaces, FDA approved seals, high finish and mechanical strength, meet the demands from food and sanitary applications.

CTS I with AISI 316L chemical resistance and mechanical strength is a reliable choice for industrial applications.

The self-priming feature allows to use the pump in applications where standard CT pumps do not prove useful. The CTS pump is capable of creating up to 4,5 m of suction lift.



How it works

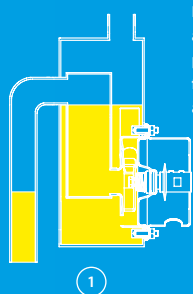

In order for the priming action to be achieved, the pump casing has to be filled with liquid to a level above the impeller.

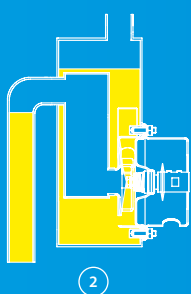

When the pump starts its operation, it is slowly sucking out the air from the suction line thus creating negative pressure and lifting the product. The air is mixed with the liquid in the pump casing. The air escapes the casing through the discharge line while the liquid returns to the impeller as it has a higher specific gravity than the liquid/air mixture.

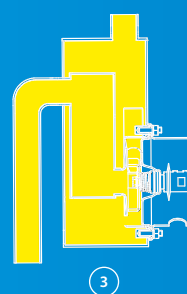

This process continues until the suction line is completely free of air and the pump can operate as a standard centrifugal pump.

Self-priming vs. standard centrifugal pump comparison

The CTS pump is a great alternative to our standard CT pumps when the self-priming ability is needed.

By replacing only one element - the casing with a self-priming chamber – we can achieve various advantages for our pump.

The pump can now suck the liquid from a lower level than it is positioned or handle liquids with high content of air.

The construction of the pump chamber ensures that there is always enough liquid left inside in order to prime the pump after stoppage.

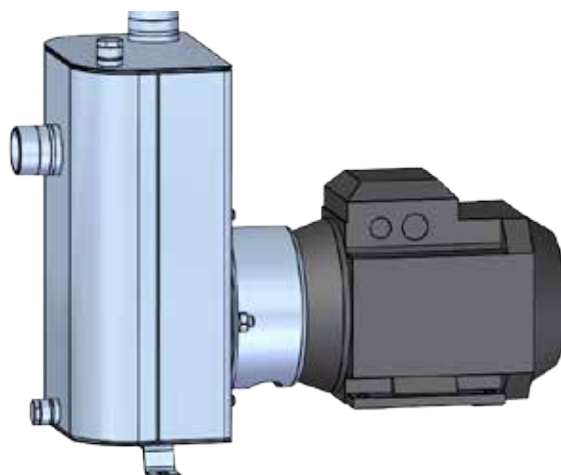

■ Features

- ✓ Wide range of optional executions: lubricated seal for safety, foot valve for quicker starting after stoppage of the pump, appropriate for hygienic applications (CTS H series).
- ✓ No need for additional pumps or equipment for self-priming.
- ✓ Ideal for highly aerated liquids.
- ✓ Easy installation and maintenance. Only the suction pipe has to be immersed and the pump can be located at a convenient spot. Disassembly of the pump can be done without interfering into the piping.
- ✓ Replace only one part on your CT pump to achieve the self-priming ability.

Installation example

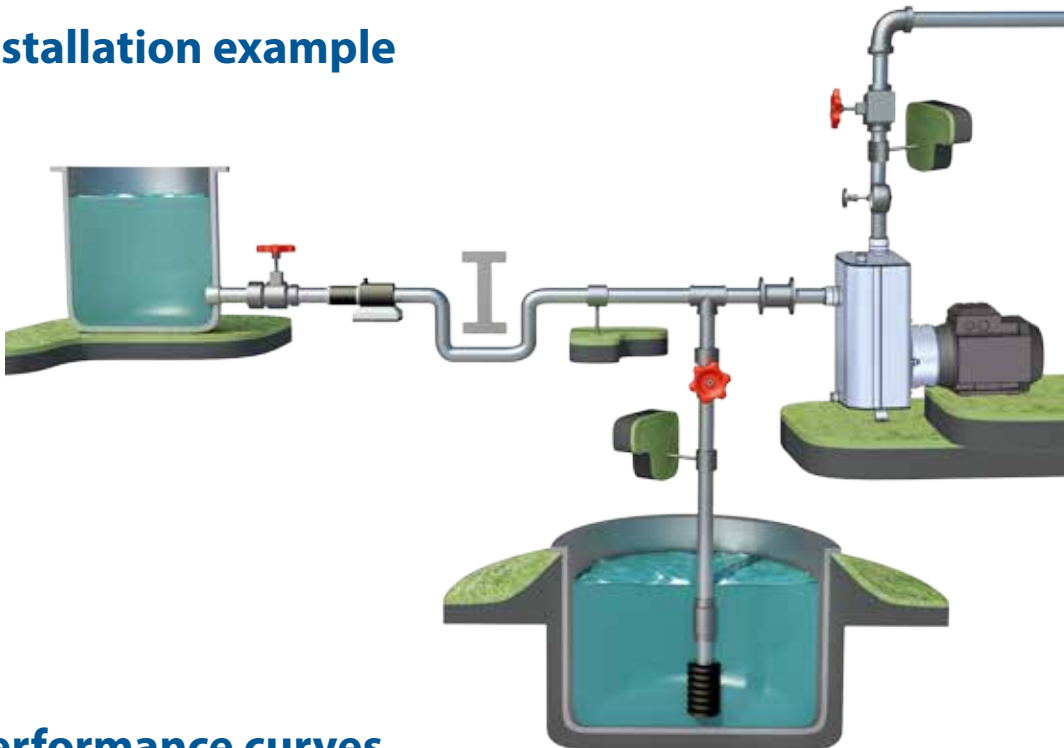

Performance curves

The performance curves are based on water at 20°C. Other circumstances will affect the performance. These curves are only for first selection, contact us for detailed curves with required power, NPSH etc.

With 2900 rpm motor

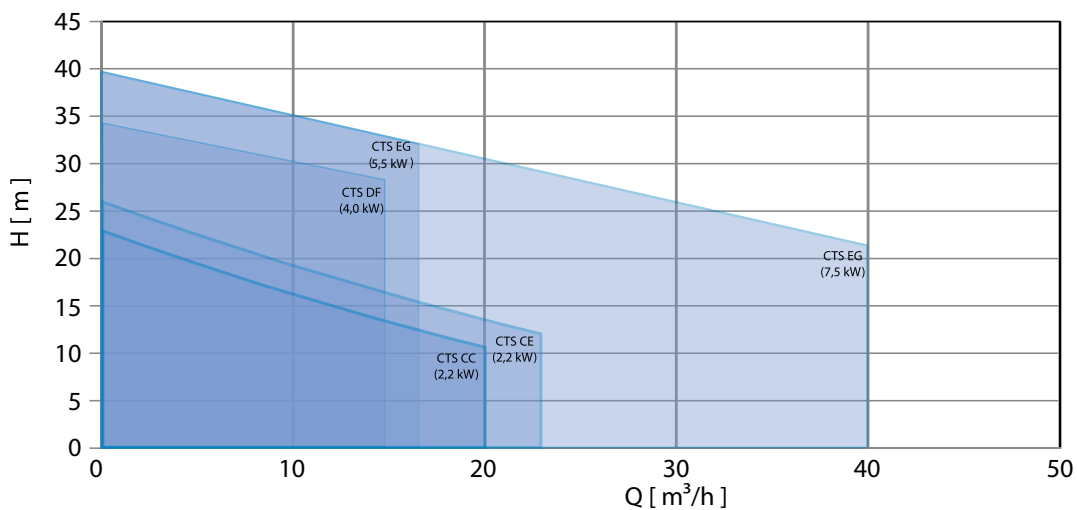

■ CTS Pump code

The details, specification, size and materials of the major components.



* = Ask us for complete pump code with all available options and executions. Changes reserved without notice

CTS pumps execution versions

✓ Standard ✓ Option



USP VI approved materials

U.S. Pharmacopeial Convention (USP) class I to VI defines how a plastic or rubber material may be exposed of human tissue. Class VI requires the most stringent testing and such materials may be used for example in implant devices.

CTS-H

CTS-I



FDA §21 CFR 177 materials

FDA (U.S. Food and Drug Administration) §21 CFR 177 lists polymers, e.g. rubber and plastic materials approved for equipment in contact with food products.



EN 10204

EN 10204 material traceability

The EN 10204 norm gives you a checklist and traceability of materials used in the equipment. 2.1 is a general statement of compliance with material specifications, while 3.1 provides specific track records all the way to the steel mill batch (normally only on metals in contact with the product).



EN 1935/2004 regulation

This EU regulation applies to all food contact materials, e.g. metals, plastics and rubber materials. It requires that these materials are safe, are labeled with the glass-and-fork symbol, are traceable throughout the production chain (according to above EN 10204) and that they are produced according to good manufacturing practice (GMP).



CE compliant

A product classified as machinery that carries the CE mark fulfill the essential health and safety requirements of the EC Machinery Directive 2006/42/EEC.



ATEX Directive 94/9/EC

Equipment intended and approved for safe operation in potentially explosive atmospheres. The equipment is divided in main groups, categories, apparatus groups and temperature classes to define its suitability in the actual zone.



CTS pumps - technical data

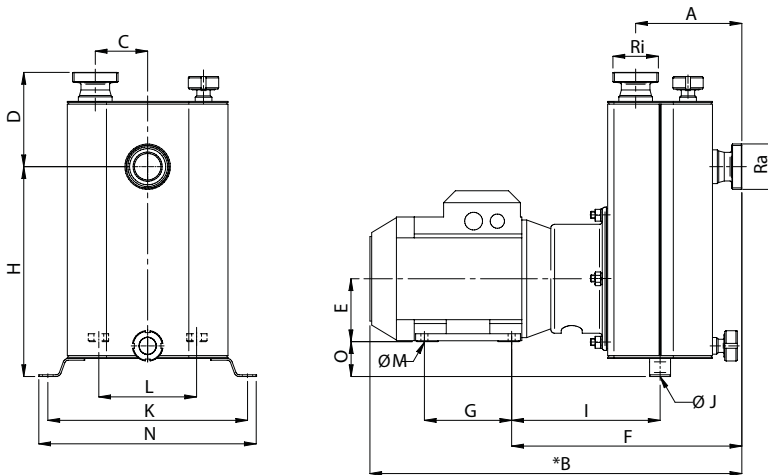

Connection dimensions

Connection dimensions BSPT (male thread)		
Model	Ra	Ri
CTSI C..	1 1/2"	1 1/2"
CTSI D..	2 1/2"	2"
CTSI E..	2 1/2"	2"

Connection dimensions DIN 11851 (male thread)		
Model	Ra	Ri
CTSH C..	DN40	DN40
CTSH D..	DN65	DN50
CTSH E..	DN65	DN50

General dimensions

Note: Dimensions in table are the same for CTSH and CTSI

Model	Motor power (kW)	IEC motor size	A	*B	C	D	E	F	G	H	I	ØJ	K	L	ØM	N	O
CTS CC-22	2.2	90	152	532,5	75	135	90	329,5	125	300,5	212,5	9	286	140	10	311	50
CTS CE-22	2.2	90	152	532,5	75	135	90	329,5	125	300,5	212,5	9	286	140	10	311	50
CTS DD-40	4.0	112	170	641	90	120	112	378	140	377	243	9	336	190	12	362	55
CTS DF-40	4.0	112	170	641	90	120	112	378	140	377	243	9	336	190	12	362	55
CTS EF-55	5.5	132	170	692	90	120	132	414	178	377	279	9	336	216	12	362	35
CTS EG-55	5.5	132	170	692	90	120	132	414	178	377	279	9	336	216	12	362	35
CTS EF-75	7.5	132	170	692	90	120	132	414	178	377	279	9	336	216	12	362	35
CTS EG-75	7.5	132	170	692	90	120	132	414	178	377	279	9	336	216	12	362	35

*This dimension may vary depending on motor brand

Materials, data and limits

Model	CTS-H	CTS-I
Casing	Stainless steel AISI 316L electro polished Ra <0.8	Stainless steel AISI 316L glass blasted
Impeller	Stainless steel AISI 316L electro polished Ra <0.8, open (standard) or optional semi open type	Stainless steel AISI 316L glass blasted, open (standard) or optional semi open type
Mechanical seal	Single ceramic/graphite (standard), SiC/SiC or SiC/graphite optional with oil lube	Single ceramic/graphite (standard), SiC/SiC or SiC/graphite, optional with oil lube
O-rings	EPDM FDA approved (standard), or FEP/silicone FDA approved	EPDM (standard), FKM, FEP/silicone or NBR
Motor	IP55, IEC frame B3/B14 (B3 on long coupled version). Available with ATEX cat 2 or 3, Eex e or Eex d motor	
Max pressure	2,6 bar (CTS C); 4,5 bar (CTS D,E)	
Temperature	max 90°C	
Viscosity	max ~200 cSt	
Particles	max diameter is 6 mm (with standard open impeller), bigger if soft particles	

Options and special executions

Lubricated seal (CTS I and CTS H)

A great option where there is a potential risk of dry running, or where the product tends to solidify or crystallize. An oil chamber is connected to the mechanical seal chamber.

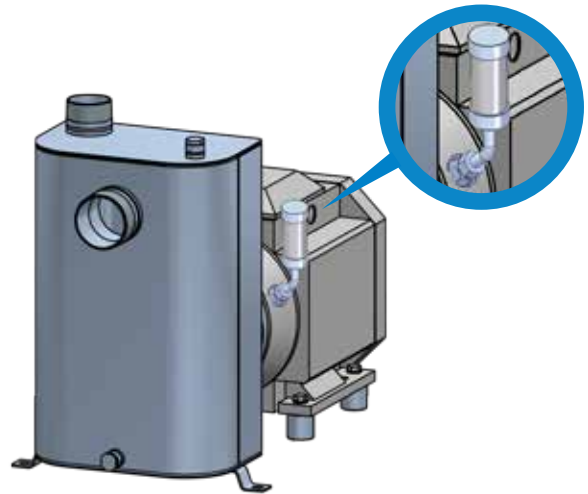

Hygienic shroud (CTS H)

The motor shroud is made of polished AISI 316L stainless steel and protects the electrical motor from splashing liquid. It also allows easy cleaning of the pump assembly.



Ingenious design

A very simple and ingenious design, easy and quick maintenance, in many cases completely maintenance free. The effect is very short down time and extremely low maintenance costs.

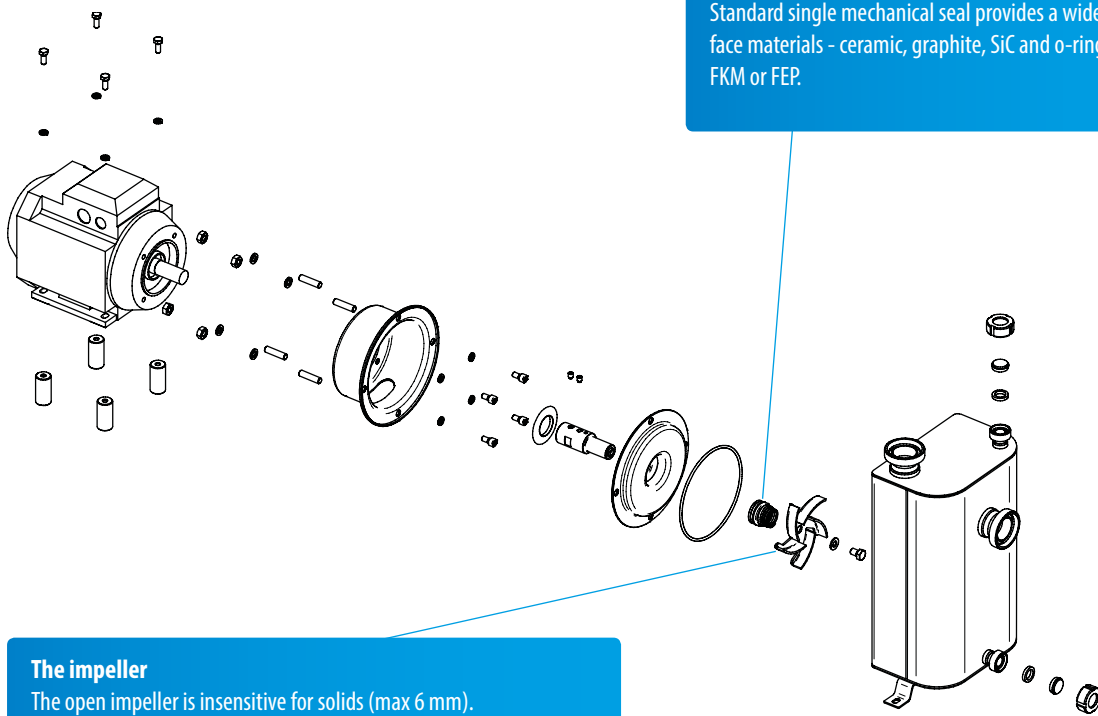

Mechanical Seal

Standard single mechanical seal provides a wide range of seal face materials - ceramic, graphite, SiC and o-rings in EPDM, FKM or FEP.

The impeller

The open impeller is insensitive for solids (max 6 mm).
Semi open impeller for heavy duty applications is available as option

Wide range of applications

The CTS-I series has a very wide range of applications – from transfer of water, to pumping of mild chemicals. Together with the hygienic CTS - H series, the number of applications within food, beverage and pharmaceutical industries increases significantly.



Food & beverage

CTH series

Transfer of various ingredients and products like edible oil, flavor, alcohol, dairy products and juice. CTH pumps are also a perfect choice for many applications like transfer of CIP liquids, detergents and water.



Chemical & pharma

CTI & CTH series

Transfer of a variety of mild chemicals and solvents.



Mechanical industry

CTI series

Handling of oil, lubricants, coolants and detergents etc.

TAPFLO AB

Sweden

Filaregatan 4 | S-442 34 Kungälv

Tel: +46 303 63390

Fax: +46 303 19916

E-mail addresses:

Commercial questions: sales@tapflo.com

Orders: order@tapflo.com

Tech support: support@tapflo.com

Tapflo products and services are available in 64 countries on 6 continents.

Tapflo is represented worldwide by own Tapflo Group Companies and carefully selected distributors assuring highest Tapflo service quality for our customers' convenience.

AUSTRALIA | AUSTRIA | AZERBAIJAN | BELARUS | BELGIUM | BOSNIA | BRAZIL | BULGARIA | CHILE | CHINA | COLOMBIA | CROATIA | CZECH REPUBLIC | DENMARK | ECUADOR | ESTONIA | FINLAND | FRANCE | GREECE | GEORGIA | GERMANY | HONG-KONG | HUNGARY | INDIA | INDONESIA | IRAN | IRELAND | ISRAEL | ITALY | JAPAN | KAZAKHSTAN | LATVIA | LITHUANIA | MACEDONIA | MALAYSIA | MEXICO | MONTENEGRO | THE NETHERLANDS | NEW ZEALAND | NORWAY | POLAND | PORTUGAL | PHILIPPINES | ROMANIA | RUSSIA | SERBIA | SINGAPORE | SLOVAKIA | SLOVENIA | SOUTH AFRICA | SOUTH KOREA | SPAIN | SWEDEN | SWITZERLAND | SYRIA | TAIWAN | THAILAND | TURKEY | UKRAINE | UNITED ARAB EMIRATES | UNITED KINGDOM | USA | UZBEKISTAN | VIETNAM

Tapflo Group Companies

Austria Tapflo Austria Tel: +43 732 27292910 sales@tapflo.at	China Tapflo (Wuxi) Tel: +86 510 8241 7602 sales@tapflo.cn	Japan Tapflo Japan K.K. Tel: +81-3-6240-3510 tapflojp@tapflo.co.jp	Slovenia Tapflo GmbH Tel: +386 68 613 474 sales@tapflo.hr
Azerbaijan Tapflo Azerbaijan LLC Tel: +994 502660799 sales@tapflo.az	Denmark Tapflo Danmark Tel: +45 36 454600 info@tapflo.dk	Kazakhstan Tapflo Kazakstan Tel: +7 727 3278347 sales@tapflo.kz	Spain Tapflo Iberica Tel: +34 91 8093182 avives@tapfloiberica.es
Baltic States Tapflo Latvia Tel: +371 67472205 sales@tapflo.lv	France Tapflo France Tel: +33 1 34 78 82 40 info@tapflo.fr	Poland Tapflo Sp. z o.o. Tel: +48 58 530 42 12 info@tapflo.pl	South Africa Tapflo (Pty) Ltd Tel: +27 31 701 5255 sales@tapflo.co.za
Belarus Tapflo Belarus Tel: +375 17 3934609 sales@tapflo.by	Georgia Tapflo Georgia Tel: +995 577 463010 sales@tapflo.ge	Romania S.C. Tapflo Rom. S.r.l. Tel: +40 21 3451255 sales@tapflo.ro	Turkey Tapflo Makina Ltd Tel: +90 216 467 33 11 sales@tapflo.com.tr
Bulgaria Tapflo EOOD Tel: +359 (0)2 974 18 54 office@tapflo.bg	India Tapflo Fluid Handling India Pvt Ltd Tel: +91 20 65000215 ad@tapflo.in	Russia Tapflo Company Tel: +7 495 232 18 28 sales@tapflo.com.ru	Ukraine TOB Tapflo Tel: +380 44 222 68 44 sales@tapflo.com.ua
Croatia Tapflo GmbH Tel: +385 91 4884 666 sales@tapflo.hr	Ireland Tapflo Ireland Ltd Tel: +353 1 2011911 info@tapflo.ie	Serbia Tapflo d.o.o. Tel: +381 21 44 58 08 sales@tapflo.rs	Uzbekistan Tapflo Uzbekistan Tel: +998 712370940 sales@tapflo.uz
Czech Republic Tapflo s.r.o. Tel: +420 513 033 924 tapflo@tapflo.cz	Italy Tapflo Italia Tel: +39 0362307698 info@tapfloitalia.com	Slovakia Tapflo s.r.o. Tel: +421 911 137 883 tapflo@tapflo.sk	United Kingdom Tapflo (UK) Ltd Tel: +44 2380 252325 sales@tapflopumps.co.uk